

## MAN 6X2 MANUAL + 15.000 LITER - BITUM TANK

### COMMON

Price	€ 15.950,- ex VAT
Id	MA112681
Make	MAN
Type	6X2 MANUAL + 15.000 LITER - BITUM TANK
Year	2008
Mileage	1.093.784 km
Construction	Tanker
Emissionclass	4

### PROPERTIES

First registration date	15-05-2008
Fuel	Diesel
Transmission	Manual
Vehicle identification number	WMA89XZZ78W112681
Axle configuration	6x2
Axle count	3
Construction dimensions (l/b/h)	

### ACCESSORIES

- Air conditioning
- Aluminium fuel tank
- Anti-lock braking system
- Anti-lock braking system
- Central locking
- Coupling
- Cruise control
- Electrically adjustable door mirrors
- Electrically operated windows
- Fog lights
- Heavy duty engine brake
- Power take-off (PTO)
- PTO
- Radio/CD player
- Refrigerator
- Sleeper cab
- Speed limiter
- Spotlights
- Toolbox
- Vehicle heater
- Visor



MAN TGX 28.480 6X2 MANUAL + 15.000 LITER - BITUM TANK

Referentienummer: MA112681

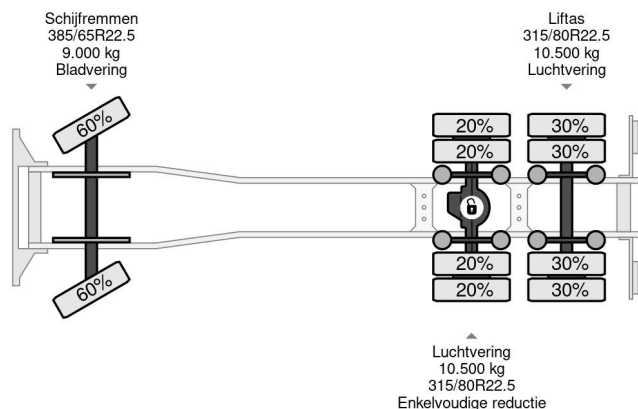

### DESCRIPTION